

REVISIONS				
ZONE	REV	DESCRIPTION	DATE	APPROVED

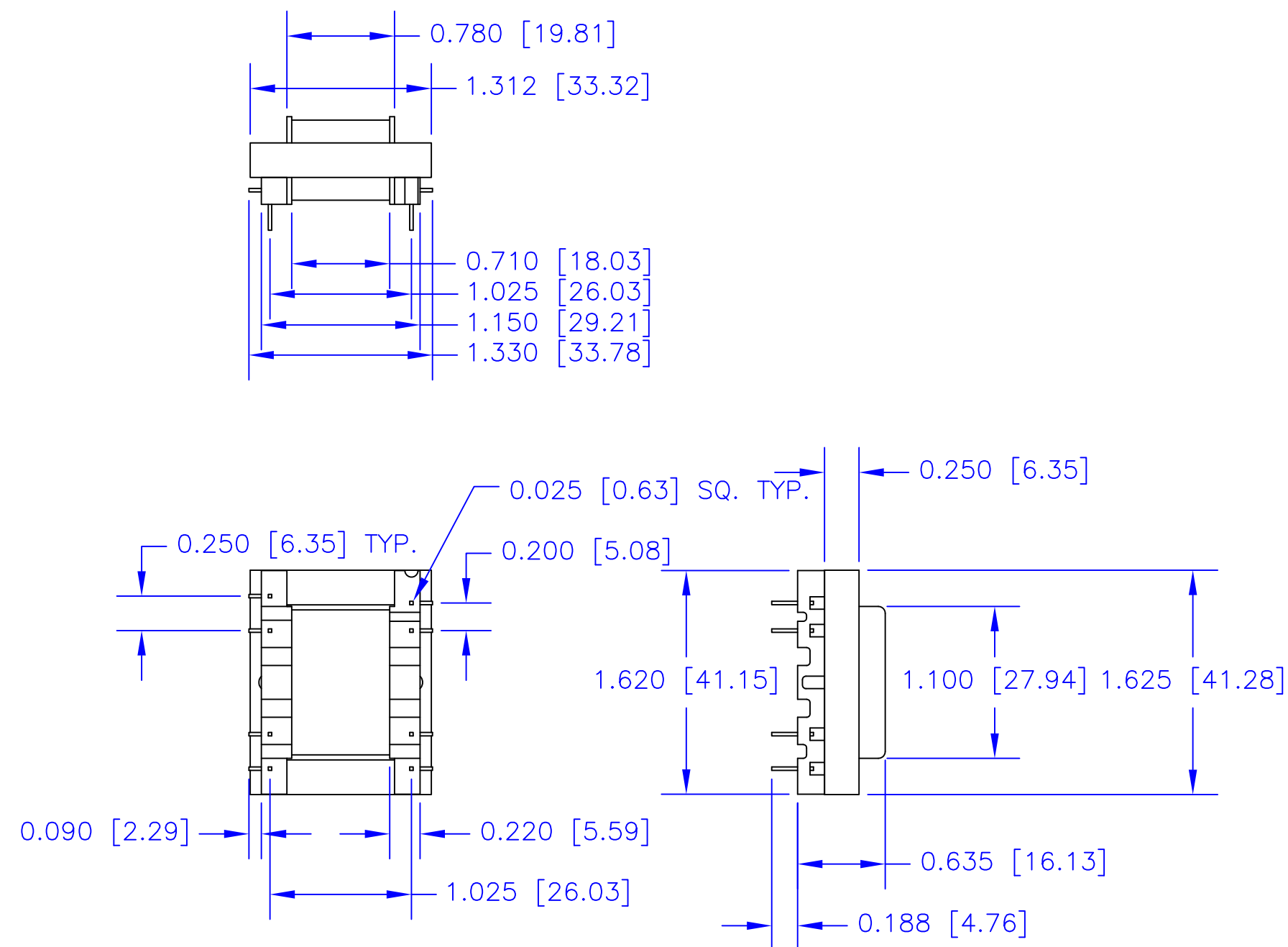

PCB MOUNTING SPECIFICATIONS

PCB NOTES:

- PIN 1 IS OFFSET FOR KEYING.
- PAD SHOULD BE AT LEAST 125 MIL. DIA.
- DRILL TROUGH HOLES SHOULD BE 55 MIL. DIA. AFTER 2 OZ. COPPER PLATED THROUGH HOLE.

**PIN ORIENTATION
(COMPONENT LAYER)**

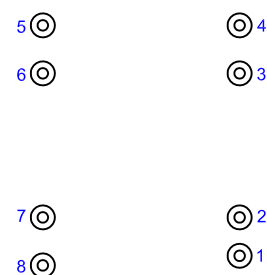

**FOOTPRINT
(COMPONENT LAYER)**

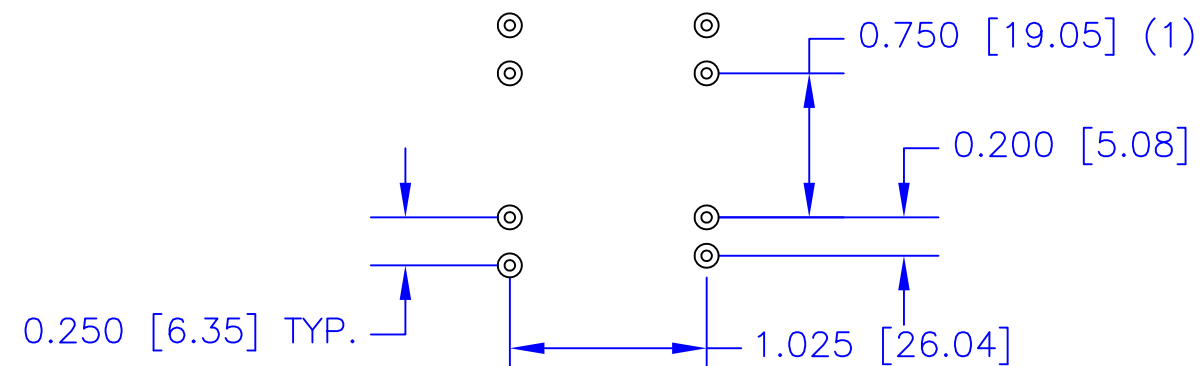

****NOTES: UNLESS OTHERWISE SPECIFIED!**

- All material is UL listed.
- All material are to be RoHS compliant.
- Bobbin: Nylon 6/6 30% glass filled, Class B, Flammability 94HB UL E184262.
- Magnet Wire: Class B, UL E32638, Gauge depending on the transformer design specifications requirement.
- Finish Tape: Polyester film tape, Class 130°, dielectric strength 5000 volts, UL E17385, guide OANZ2.
- Core Material: Depending on the transformer design specifications requirement
- Termination: 8 pin PC.
- Mounting: horizontal printed circuit board.
- Finish: Styrenated alkyd electrical varnish, air cured, UL E63933.

DIMENSIONS ARE IN INCHES (MILLIMETERS). X.XXX = ±0.010 X.XX = ±0.03 ANGLES = ±0.05 UNLESS OTHERWISE SPECIFIED		EDCOR Electronics 7130 National Parks Highway, Carlsbad, NM 88220 Voice: (575)887-6790 Fax: (575)887-6880 www.edcorusa.com		
DRAWING BY Brian Weston		Date 9/2003	horizontal PCB mounted	
CHECKED BY Brian Weston	Date 9/2003	SIZE C	FSCM NO.	DWG NO. 15000-EI050-025-P08
APPROVED BY Larry Weston	Date 9/2003	SCALE: 1:1	©2010 EDCOR Electronics	SHEET: 1 of 1